



BRICK FACINGS GUIDE

01 Introduction.....	2	06 Benefits.....	10
02 Dimensions.....	3	07 Installations.....	11
03 Colours.....	4	08 Warranties.....	14
04 Performance.....	8	09 References.....	14
05 Applications.....	9		

01 INTRODUCTION

BRICK FACINGS

Australia’s leading range of quality clay bricks are now available as brick facings.

Brick facings allow you to achieve the timeless beauty and durability of real bricks with the advantage of light weight and easy installation.

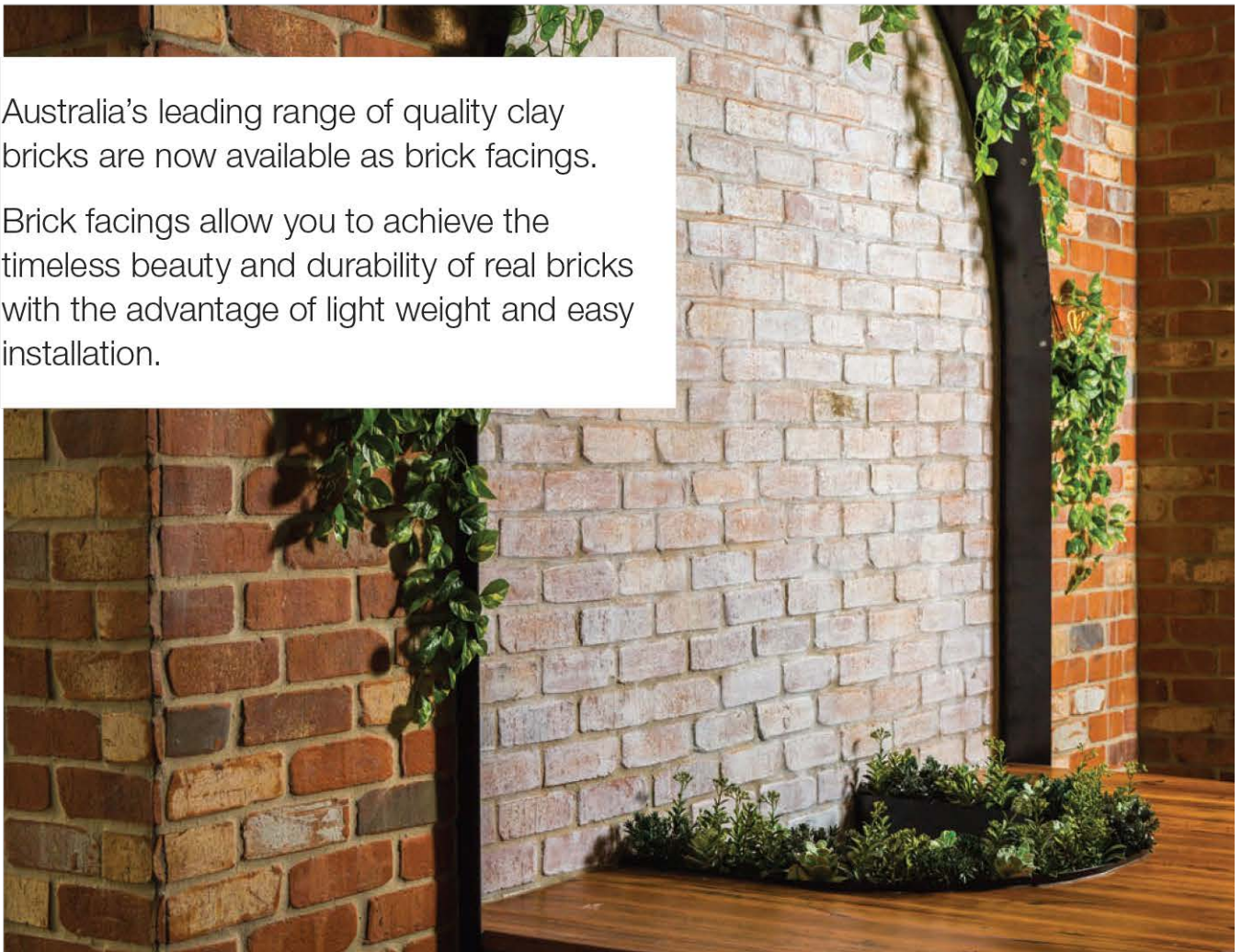

DIMENSIONS

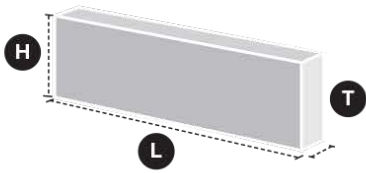
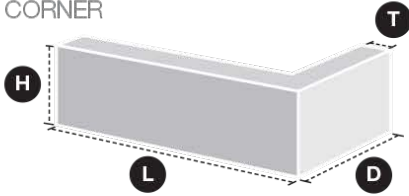

		L LENGTH	D DEPTH	T THICKNESS*	H HEIGHT	
FACE		STANDARD	230mm	–	18mm	76mm
		LINEAR	287mm	–	18mm	48mm
CORNER		STANDARD	230mm	110mm	18mm	76mm
		LINEAR	287mm	90mm	18mm	48mm

*Actual product dimensions may vary slightly

Note that variations in dimensions must be allowed for during the installation process. The weight of Brick Facings should be based on the cut tile thickness, rather than 110mm thick AMS bricks.

COLOURS

You can choose from a wide selection of available stocked ranges:

Coastal Hamptons - conveys relaxed, welcoming style of the Australian coast and beach.



Washed White

Connoisseur - suitable for various design aesthetics



Angasi



Chai



Granita



Liquorice



Panna Cotta



Walnut

Dry Pressed Architectural - luxury and style in Australian-made clay brick product

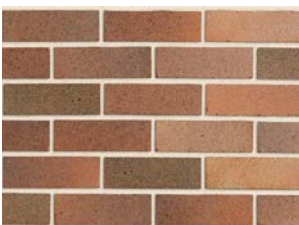

Bradfield Bronze



Macquarie Blend



Monash Grey



Silver Shadow



Tinto Cream

Glazed - a striking selection of accent colours, perfect for indoor or outdoor features walls



Ashen (Grey Gloss)



Ficus (Green Gloss)



Marigold (Yellow Gloss)



Orchid (Blue Gloss)

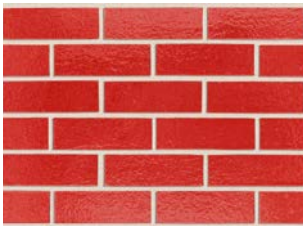

Poppy (Red Gloss)



Snowdrop (White Gloss)

Lang Mursten - Exquisitely crafted long-format Danish bricks, blending cutting-edge design with practical functionality.



Gehl



Larsen



Lund



Rosenberg



Utzon

Manhattan - when light hits the velour surface it creates wonderful depth variation



Brooklyn



Tribeca



Bullarav



Mandu

Manor - offers a soft cream colour palette in standard and double height bricks

Metallic - an ultra-premium finish for modern, stylish statements



Apollo



Blue Steel Flash



Matterhorn



Mercury

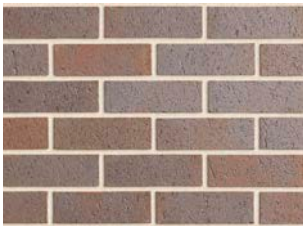

Nickel Flash



Olympus

Morada - high-end luxury with a smooth finish that creates an impressive brick flooring design



Ares



Ares Linear



Blanco



Blanco Linear



Cacao



Cacao Linear



Ceniza



Ceniza Linear



Nero



Nero Linear



Nero Gloss



Nero Satin

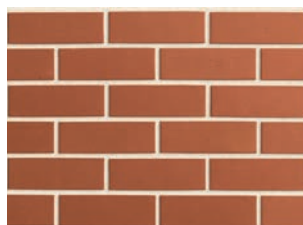

Rojo

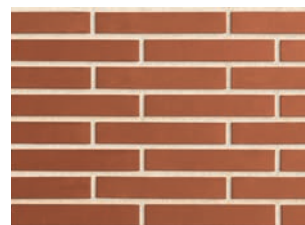

Rojo Linear

Nightfall - selection of dark-toned bricks designed to add depth and drama to architectural designs



Haze

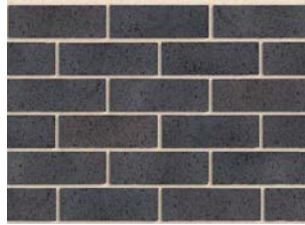

Midnight



Tempest Blue



Wolf

Origin - selection of staple brick colors, including tans, browns, and greys.

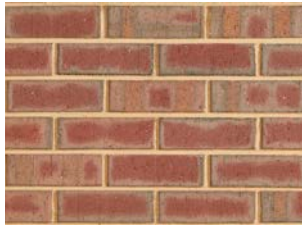

Grampian Blue

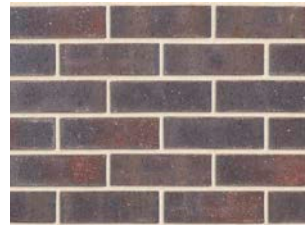

Mystique

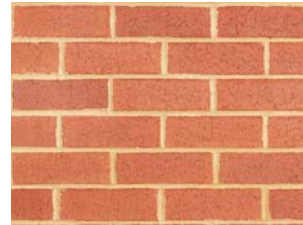

Olde Red

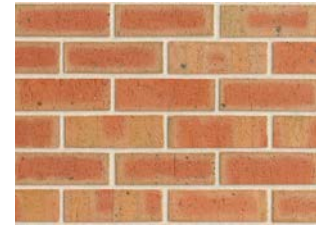

Red Clinker

Smooth - known for beautiful clean lines, smooth-face textures

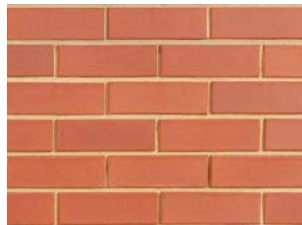

Adelaide Red



Flannel Grey

Velour - an authentic, urban industrial warehouse aesthetic fueled by the industrial chic-movement



Crushed Grey

PERFORMANCE

AMS Surfaces all clay fired masonry products satisfying the requirements of the Australian and New Zealand Standard, AS/NZS 4455 – Masonry units, pavers, flags and segment retaining wall units. Products are tested to the Australian and New Zealand Standard AS/NZS 4456 – Masonry Units, Segmental Pavers and flags – Methods of Test. The testing is carried out in our AMS Surfaces NATA accredited laboratory.

Slip Resistance

Brick facings cut from AMS standard brick range were tested through AS/NZS 4586 - Slip resistance classification of new pedestrian surface materials, and most products achieved the highest grade of slip resistance P5.

Corrosion resistant

Brick is an extremely durable product that can withstand abrasion from foot traffic. AMS bricks are tested to AS 4456.10 - Masonry units, segmental pavers and flags - Methods of test - Determining resistance to salt attack, most achieved exposure grade which is a good indicator for its performance under extreme environment.

Acoustic

The heavy mass and porous nature of clay brick adds extra acoustic insulation to your wall or floor, particularly for low frequency noise.

Fire Resistance

The fire performance of floor and walling materials must comply with minimum requirements set out in the National Construction Code (NCC / BCA). Masonry (clay brick) is recognised as a non-combustible material under the NCC. It is also generally accepted that fired clay masonry units are non-combustible and will remain stable during a fire, they will not contribute to the spread of fire or produce smoke or toxic gases. This is because during the manufacture of AMS Surfaces bricks, they are fired in kilns at in excess of 1100°C without combusting.

Safe Working Practices

Clay products contain silica and can generate crystalline silica dust when cut. Wet cutting is the recommended cutting method for all clay products. PPE must be worn and cutting must be outdoors as a minimum control. Follow [Management of Silica Dust on site](#) by Think Brick Australia.

Weather Barrier

Bricks are not waterproofed. As a result, brick facings are NOT recommended in wet areas without additional AS 4858-compliant waterproofing treatment designed and installed in accordance with the waterproofing standard, AS 3740 and the NCC.



APPLICATIONS

AMS Surfaces recommends consulting project designers, sealant and adhesive manufacturers for recommendation to suit the specific requirements of each project.

ILLUSTRATION OF TYPICAL BRICK FACING FLOORING AND SUBSTRUCTURE

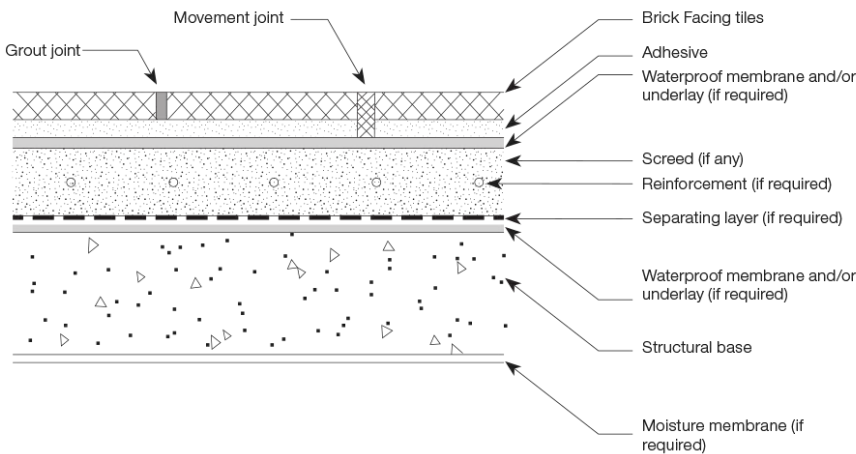

Flooring – Internal and External General Applications

Brick facings are an ideal and durable covering on either internal or external floors. A brick facing laid as flooring is suitable for pedestrian traffic areas (with light foot traffic or the passage of lightweight soft-wheeled trolleys) and must be bonded by suitable adhesive to a solid concrete base. Joint between brick facings should be filled.

Walling – Internal and External

Brick facings on wall applications require a solid substrate such as a concrete or fibre cement stud wall. For height and wind load limit on wall applications, consult adhesive manufacturers for information.

CONCRETE/MASONRY APPLICATION

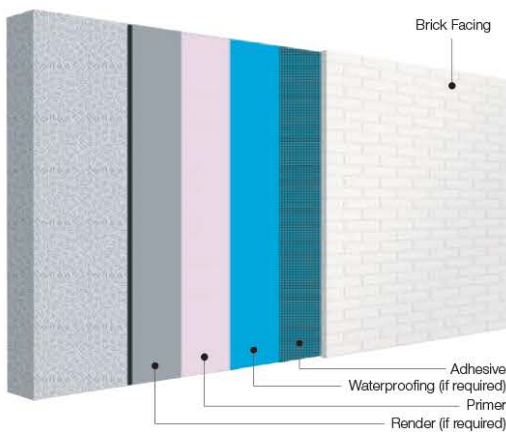

STUD WALL APPLICATION

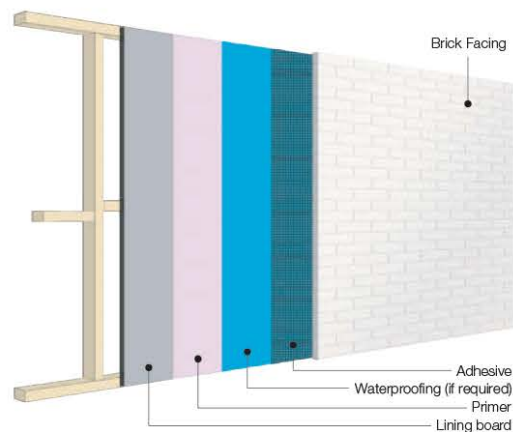

Limitations

Adhesive, grout, fixative and primer products and their use for wall and floor tiling application should conform to AS 3958.1 and AS 3958.2. Guidance should be sought from the manufacturers of the relevant products appropriately.

When a separating layer is used between brick facing and substrate, the sliding action between the two elements should be prevented.

AMS Surfaces Brick Facings are limited for use as non-structural tiling materials relying on rigid structural layer.

They are NOT suitable for use:

- on flexible or brittle substrate such as Gyproc walls;
- in wet areas (without suitable waterproofed membrane);
- where wind load is likely to exceed 3kPa.

For flooring application, it is also recommended that flooring with Brick Facings are not used for vehicle traffic. Examples of unsuitable applications include driveway or garage floor.

BENEFITS



- Real brick finish in a range of design scenarios with flexible brick patterning
- Match interiors and exteriors through seamless integration with traditional masonry.
- Lightweight, easy to use and simple to install
- Onsite flexibility enables shaping to suit building details and achieve seamless brickwork around corners, windows and doors
- Can be fixed on most common substrates
- Low maintenance, durable

INSTALLATIONS

Step 1. Product and laying patterns selection

Refer to Section 3 for Brick Facing colours. In some cases, selection will be influenced by factors such as the suitability of the existing floor as a sub-base.

Flooring:

- (1) Running bond
- (2) Stacked bond
- (3) Basket weave
- (4) Diagonal basket/ fishbone/ herringbone weave

Walling:

- (1) Stretcher bond
- (2) Stacked bond
- (3) Textured surface
- (4) Mixed colour pattern



Running/Stretcher



Stacked / Stack



Herringbone

Step 2. Design considerations

The provisions affecting finishes can be found under the 'general provisions', 'health and amenity', and under 'fire resistance' sections of NCC/BCA. Practitioners must design in accordance with the relevant provisions as a minimum requirement.

The project designer's opinion should be sought for any structural or environmental conditions such as the likelihood of ground movement, exposure to hazardous chemical, deflection or of excessive or delayed shrinkage onset of the substrate. Where floor set-downs and falls of slabs are required to accommodate the combined thicknesses of screeds to falls, tiles and bedding, these should be resolved early in the project.

All substrates must be robust on their own and capable to take the additional load from brick facings. AMS Surfaces brick facings are not intended for providing structural function, and rely on a rigid base to take the wind / earthquake (when used on walls) or traffic load (when used as flooring).

Brick facings, their fixings and grouting mortars do not constitute a waterproof barrier.

When brick facings are used as flooring, the subsurface drainage should be designed by a qualified civil engineer.

Step 3. Substrate preparation

The surface being adhered to must be clean, firm and free of dust, dirt, oil, grease, curing compounds, release agents and other barrier materials, as well as being strong enough to support the weight of the tiles being fixed. The wall and slab construction must be in accordance with the relevant Australian and Industry standards. Ensure surfaces are dry before tiling, with no residue or permanent damp.

For floor covering installation, whether the slab is new or existing (in this case, only when the brick facing are not cut to cores), most adhesive, levelling compound, moisture barrier, etc. manufacturers require a specific surface profile for their products to bond / adhere to and surface preparation to achieve a specific Concrete Surface Profile (CSP). Please consult the manufacturers and follow their product specification.

Do not install your thin bricks over the top of vinyl, tiles, or any other finished floor or wall surfaces. Existing tile or other wall/ floor covering will need to be removed first.

Brick facings cut to cores must be embedded into the substrate in a manner that the cores are entirely filled with grout, bonded to and supported uniformly by substrate to avoid unevenly distributed load transfer, which may cause cracking.

Before starting, substrates must comply with the maximum allowable deflection criteria in accordance with the relevant Australian Standards or the applicable local building code. The base for brick facings should be a rigid and properly cured structural slab. The concrete rigid base should be designed in compliance to AS 1884, AS 2870, AS 3600, section 4.3 of AS 3958.1 and relevant legislations by project professionals, whilst being at least 75-100mm thick to achieve strength consistent with expected traffic loading (in general terms, min. 20MPa). When AMS Surfaces brick facings are used to cover areas greater than 16m², including a layer of reinforcing mesh SL92 is recommended to mitigate shrinkage effect.

Step 4. Expansion and control joints

Thermal and long-term moisture expansion of clay materials must be considered when designing a wall or floor with brick facings. The project designers should be consulted for advice on the location of such expansion joints. For movement joints made of sealants, they should be capable of expanding, to allow the full movement anticipated in the joint without failure of adhesion.

The expansion rate of AMS Surfaces bricks were tested to AS 4456.11. The thermal expansion of clay masonry units varies slightly depending upon their colour and the method of manufacture, but the value is unlikely to be greater than 0.008 mm/m/°C.

Project professionals must include intermediate movement joints considering the thermal expansion of brick tiles when designing wall or floor tiling using AMS Surfaces brick facings. Existing joints in subsurface must be carried through the brick facing tiling work and must conform to architectural details.

Expansion joints must be installed at all "changes of plane". As a minimum requirement AMS Surfaces recommends movement joints be inserted at evenly spaced positions at 4.5 m centres or at locations where stress might reasonably be expected in:

- (a) internal floors where any dimension exceeds 9 m or 6 m if subjected to sunlight (clause 5.4.5.2(b)(i) of AS 3958.1);
- (b) external floors where any dimension exceeds 4.5 m (clause 5.4.5.2(b)(ii) of AS 3958.1).

If the upper layer of waterproof membrane and / or underlay is not installed, the movement joint must continue through the screed.

Refer to AS 3958.1 for industry recommendations.

Step 5. Adhere Brick Facings over a rigid base

There are many adhesives available and the most suitable is dependent on the specific requirements of each project. Variables to consider include the height, service conditions, intended location (wet or dry, external or internal), substrate type and installation technique. Adhesive, grout, fixative and primer products used with AMS Surfaces brick facings should conform to AS 4992, AS 3958 and guidance should be sought from the manufacturers of the relevant product's suitability.

Follow the adhesive manufacturers installation method. As a general guide, a cement-based tile adhesive should be applied using a 10 to 12mm notched trowel to apply adhesive to the slab. The adhesive should cover at least 95% of the underside of the brick facing.

Step 6. Waterproof membrane

Cement-based adhesive with bonded waterproof membrane in accordance with AS 4858 is a minimum requirement when waterproof membrane is used. The relevant requirements in AS 3958, AS 3740 and AS 4858 should be considered, particularly with regard to the preparation of the background.

Waterproof membrane or moisture membrane may be used directly under / behind the brick flooring tiles or substrate.

Step 7. Grouting and pointing joint

Joints between brick facings need to be filled and it can create a traditional brick look if grout is used – they also come in different colours to achieve different looks. Joint alignment should be consistent throughout the installation within a tolerance of 6 mm in 2m for floors (clause 5.4.6(d) of AS 3958.1).

Allow the installation to cure prior to grouting /pointing joints other than movement joints. The mixture must be proprietary cementitious grout in accordance with AS 4992.3 and must have low shrinkage and good adhesion to the sides of the joints. Please follow the manufacturers guidelines regarding usage and cleanup of excess mortar or grout.

Step 8. Sealants

For ease of cleaning and to provide extra protection and moisture barrier to your wall or floor, AMS Surfaces recommends applying a suitable sealant, especially for flooring applications.

Sealer products used with brick facings should not contain chemical that may adversely affect the bricks, particularly for flooring – slip resistance.

Flexible or waterproof sealants are defective if they are not installed in accordance with the BCA/NCC and AS 3958.1, or when not meeting AMS Surfaces's installation requirements.

Follow the adhesive and sealant specifications for the drying and curing period.

Step 9. Finish and cleaning

Remove excess grout without damaging the brick facings after the filling of the joints is complete. Follow the adhesive manufacturer's instructions for curing time. As a general recommendation, foot traffic should be limited from traversing the brick facing flooring for at least four days.

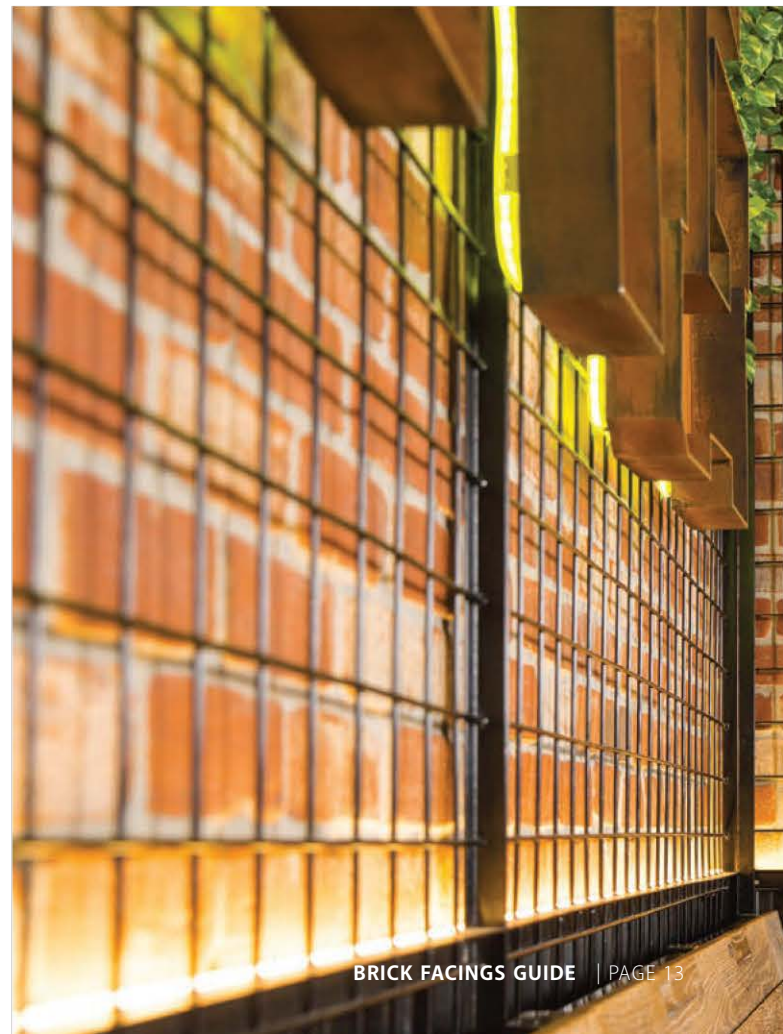

WARRANTIES

Refer to AMS Surfaces Product Warranty for more information.



REFERENCE

- AS/NZS 4455 – Masonry units, pavers, flags and segment retaining wall units
- AS/NZS 4456 – Masonry Units, Segmental Pavers and flags – Methods of Test
- AS 3958.1: Ceramic tiles – Guide to installation of ceramic tiles
- AS 3958.2: Ceramic tiles - Guide to the selection of a ceramic tiling system
- NCC/BCA: National Construction by Australian Building Codes Board
- AS 3740: Waterproofing of domestic wet areas
- AS 4858: Wet area membranes (Reconfirmed 2020)
- AS 1884: Floor coverings - Resilient sheet and tiles - Installation practices
- AS 2870: Residential slabs and footings
- AS 3600: Concrete structures
- AS/NZS 3837: Method of test for heat and smoke release rates for materials and products using an oxygen consumption calorimeter
- AS/ISO 92391: Critical Radiant Flux test for flooring materials



contact us

South Australia

AMS Surfaces Welland Showroom
59 Grange Road, Welland, SA 5007
Telephone: +61 8 8352 1265

AMS Surfaces + Adelaide Marble Head Office
122 South Terrace, Wingfield, SA 5013
Telephone: +61 8 8345 1842

enquiries@adelaidemarble.com.au
amssurfaces.com.au

Northern Territory

AMS Surfaces Darwin Showroom
8/23 Tannadice Street, Winnellie, NT 0820
Telephone: +61 8 8345 1842